

NELSON STUD WELDING

SPECIFICATION: S3L Shear Connectors (SC)



Nelson headed shear connectors deliver code specified shear strength values as used in composite construction, securing concrete to steel structural components. Nelson shear connectors meet requirements of the following codes and are also USNRC approved:

- AWS D1.1 Structural Welding Code – Steel
- AWS D1.6 Structural Welding Code – Stainless Steel
- AWS D1.5 Bridge Welding Code /
- AASHTO Standard Specification for Highway Bridges
- ISO-13918 welding – Studs for arc stud welding
- Canadian Standards Association W59 – Welded Steel Construction
- International Building Code Section 19
- AISC Manual of Steel Construction – Allowable Stress Design
- AISC Manual of Steel Construction – Load & Resistance Factor Design

See also: ICBO Evaluation Report ER-2614 Nelson Shear Connectors

Shear connectors are typically used in composite steel construction for holding concrete slabs to steel members to resist shear forces and increase shear loading capacity in steel buildings, bridges, columns caissons, containment liners, etc. They also act as embedment anchors on miscellaneous embedded plates, frames, angles, strip plates, attachments and connections. Options for **Welding Through Metal Deck** are available for this stud.

For similar function studs, see Nelson **H4L Headed Concrete Anchors** and **D2L Deformed Bar Anchors**.

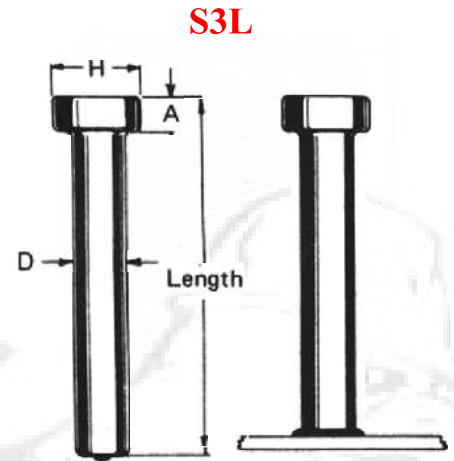

When ordering, specify Type, Diameter, Length, Material, Quantity, and Part Number

Example: S3L 3/4 x 6-3/16"; Mild Steel; 10,000 pieces; #101098015

Stud Diameter	Burn Off	A	H	Recommended Standard Accessories			
				Chuck	Foot	Ferrule Holder	Ferrule for Flat
3/4" 19 mm	0.187 4mm	0.375	1.250	500001088	502002042	501006027	100101152
7/8" 22mm	0.187 4mm	0.375	1.375	500001091	502002042	501006028	100101140
1" 25mm	0.250 6mm	0.500	1.625	500001424	502002042	501006046	100101045

* Burn Off: Burn off lengths shown are for welding to bare steel. For burn off values and other details when studs are welded through metal deck to steel see **WELD THROUGH DECK SPECIFICATION SHEET**

The **Nelson Ferrule Shooter** is available for semi-automatic dispensing of ceramic ferrules along with standard ferrules assembled 50 pieces per “string” for easy and fast loading onto the Ferrule Shooter dispenser. Following are the current ferrule assemblies available:

Stud diameter	Ferrule
3/4" downhand	100101260
3/4" weld through deck	100101249
7/8" downhand	100101261
7/8" weld through deck	100101262

MATERIALS: Studs are available in Low Carbon Mild Steel and 316L Stainless Steel. For specific grade information and physical and chemical properties, conforming standards, and information on stud plating and heat treating, please see **General Material Specifications**. Certified Material Test Reports (CMTR) and Certificates of Compliance (COC) are available and must be requested at time of order.

For ferrules and grips used in welding at an angle to plate, welding to angles, and welding to a vertical base plate, see the **Special Applications** section of the **Ferrule Specifications**.

FLUX: All Nelson concrete anchors have a solid flux load.

Visit our website www.NelsonStudWelding.com for a list of our standard stock products.